



**INTERNATIONAL JOURNAL OF ENGINEERING SCIENCES & RESEARCH
TECHNOLOGY**

**TEMPERATURE, HEART RATE MONITORING AND ECG ACQUISITION SYSTEM USING
DIE OPTICAL STEERING WHEEL SYSTEM**

M.Anandakumar

Assistant Professor, Department of Electrical and Electronics Engineering
Kalaivani College of Technology, Coimbatore
Tamilnadu, India

ABSTRACT

This work presents a temperature, heart rate monitoring of human body in easy way and fast acquisition of electrocardiogram (ECG) signal by using die pole steering wheel system. The system detecting the ECG condition of patient using die pole wireless steering wheel system and send to patient through Bluetooth. This system reduces frequency interference and it is able to show stable ECG signal with good quality for monitoring purpose in less time. Heart rate detection algorithm based on the continuous wavelet transform has been implemented, which is specially designed to be robust against the most common sources of noise and interference present when acquiring the ECG in the hands. The algorithm shows acceptable performance even under non-ordinary high levels of EMG noise and yields a positive predictively and sensitivity value when tested in normal use with subjects of different age, gender, professionals and physical condition.

KEYWORDS: Electrocardiogram (ECG), Die optical, Electromyography (EMG), Body Temperature sensor

INTRODUCTION

The population of human being is expected to cause a significant increase in medical expenses in the next years. In the Indian country, for instance, the population over 50 years will be around 140 crores of people in 2025 and medical expenses are expected to grow from 10% to 22%. Other regions are also expected to follow similar trends. This scenario has fostered the development of many novel techniques for noninvasive physiological monitoring intended to perform periodic measurements of basic physiological parameters at home or in other non-clinical environments. These parameters have been proven to be very valuable to assess individual wellness and a long term analysis of this kind of data has been proven to be of great help in preventing possible future disorders and diseases and consequently in reducing the overall medical costs. Furthermore, these techniques can allow a more frequent supervision of patients with health Troubles or also can allow patients to make part of the hospitalization at home, hence reducing the hospital occupancy and improving their quality of life. Prevention is especially critical for cardiovascular diseases and electrocardiogram (ECG) is the most undisputed and widely accepted tool to detect and diagnose them. Historically ECG machine were confined to heart stations, cardiology

departments in hospitals. This states gradually changed .ECG moving into noncardiology departments such nursing, emergency department, electrophysiology lab and respiratory therapy.

In the past few years a remarkable progress has been made in the design of sensors for wearable devices. Nevertheless, the existent devices are difficult to integrate, mainly due to the quantity of electrical interconnections and components required at the sensing places. Enormous impact in older people life expectancy, cardiovascular diseases are also the main cause of death for the population among 44 and 64 years and detecting their symptoms in time is critical to avoid irreparable damages or death. Nevertheless, methods and systems to acquire an ECG signal with good enough quality in a fast and easy-to-use manner, so that they can be used in domestic or other non-clinical environments, are nowadays far from common. This is mainly because traditional ECG acquisition systems usually require the use of several cables and electrodes attached to the body, sometimes with conducting gel to increase the contact, making them embarrassing and difficult to use. Furthermore, most of these systems have the additional drawback of being unable to transmit or store digitalized data. Some of these problems have been reduced in the

recent times by implementing wireless ECG systems. In spite of this, most of them still use wet electrodes and conducting gel, whereas only few avoid some of the discomfort problems of the formers, by using other type of electrodes, mainly capacitive. Nevertheless, as most of these systems are designed to be worn on the thorax, they require a considerable preparation time and skill to acquire the ECG signal. Although this could be a minor drawback for long-term monitoring, it makes most of these methods less practical for fast short-term or periodic monitoring.

PRESENT SYSTEM DESIGN

In present system wireless system to perform fast short term ECG acquisition and heart rate monitoring intended to be easy to use for non technical users. The system uses dry electrodes placed on a plastic steering wheel so that the Lead I ECG signal is acquired in monitor mode simply by placing the hands on it. Although dry electrodes minimize preparation time, they can suffer from a higher level of power line 50/60 Hz interference compared to other types of electrodes especially when used in short term measurements.

overcome this drawback, they have used the dual ground configuration in which two signal and two ground electrodes are placed symmetrically in the battery-supplied steering wheel. This configuration has the advantages of both reducing the 50/60 Hz interferences and also of avoiding the use of an electrode in the right leg. The steering wheel has been designed as a wireless node that acquires and transmits the ECG signal to an access point connected to a personal computer. The PC is in charge of processing and displaying the ECG with the heart rate from the ECG signal, the system implements a novel algorithm based on the continuous wavelet transform (CWT), which has been designed and tested to offer a robust performance against electromyography (EMG) noise and baseline wandering, which are the most common noise and interference sources when acquiring the ECG in the hands. The main drawback of this system is high harmonic will be presented and complicated filter design.

PROPOSED SYSTEM DESIGN

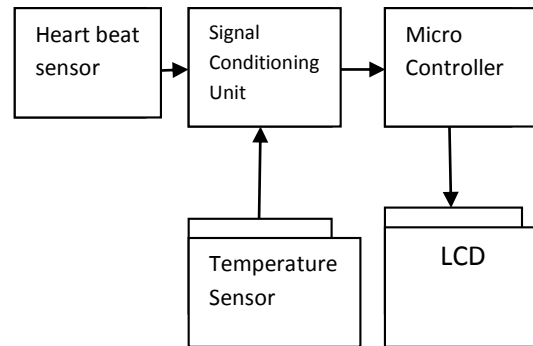

Fig .1. Block diagram of proposed system

Fig. 1 shows the block diagram of the proposed system. The minimal configuration consists of one steering wheel wireless node and one access point connected to a personal computer. In the wire- less node die optical system is to measure the Lead I ECG in the hands. The ECG signal measured is band-pass filtered and amplified prior to be acquired with the analog-to-digital converter (ADC) of a low-power microcontroller and to send it to the access point by means of a RF transceiver. The access point transmits the data to a PC which is in charge of displaying the ECG signal and of implementing the novel heart rate detection algorithm. The proposed system is introduced the electronics data of patient will be send to mobile phone through SMS. Next sections are devoted to provide extended details of each constitutive part of the system.

A .Die optical Steering Wheel

A die optical device mounted on a plastic wheel according to the ground configuration. In this configuration, a die optical device is placed very close to each of the two recording devices. Using this configuration has the advantage of a reduced harmonics interference with respect to the typical die optical configuration for the Lead I ECG, which uses one ground electrode placed in the right leg. Furthermore, this configuration has the key advantage of allowing us to acquire the EGC signal simply by placing the left and right hands on die optical with no right-leg electrode and without any previous preparation procedure and send the SMS to the patient immediately. The proposed system is a new technology to offer the very accurate measurement of temperature, heartbeat of the human body, the analog front end employs several consecutive stages to filter and to adapt the Lead I ECG signal level to that of the ADC. Following the

signal path, two buffers, implemented with the internal Op Amps available in the microcontroller, are needed first to reduce the interferences that could enter into the system due to the impedance mismatch between the electrodes. After the buffers, a first order high-pass differential filter has been used to achieve the lower 0.5 Hz limit of the desired monitoring bandwidth and to reduce baseline wandering.

The differential amplifying block is implemented using the low power instrumentation amplifier INA122 with the gain set to 520 and, after it, the higher 40 Hz limit of the monitoring mode is achieved by a Sallen-Key cell with a low-power OPA336 Op Amp, designed for battery powered applications. The common mode rejection ratio (CMRR) measured for the total circuit in the desired frequency range was about 80 dB, mainly due to the relatively low values of CMRR of this low-power instrumentation amplifier, optimized for portable devices, compared to those usual in general purpose instrumentation amplifiers.

An EZ430-RF2500 board, that comprises a MSP430F2274 microcontroller and a CC2500 transceiver, is used to implement the microcontroller and the RF module of the prototype. The microcontroller includes a 10 bits internal ADC that is used to sample the EGC signal coming from the analog front-end with a 100 Hz sampling frequency. To further increase the rejection to power line interference, a digital square filter of 2 taps is implemented, centered on 50 Hz. The node works with a single supply voltage of 3 V supplied by batteries and has a total measured current consumption of 2.5 mA. Using two standard 1250 mAh 1.5 V batteries with these consumption values, the system is expected to perform up to 3000 short ECG acquisitions of 2 min each, which is enough for short-term monitoring purposes.

B. Network Design

The system uses the Simplicity network protocol, which is a Texas Instruments proprietary implementation of the IEEE 802.15.4 Standard for low-rate wireless personal area networks, to link the wireless node to the access point. As the RF module is the most power demanding part, the wireless node program sends 10 samples on each packet to minimize the power consumption due to data transmission. Every packet is 15 bytes long and includes also information about node identification and battery level. Packets are sent every 100 ms (bit rate 1200 bps), fast enough to be observed as continuous by human perception. The access point is connected to a PC through an USB port that is

configured to transmit data at 9600 bps, thus allowing to add up to a theoretical maximum number of eight active wire- less nodes, in case that the network implementation would be used as a small Wireless Body Area Network. Lab- VIEW is used to develop the user interface in the PC to show the Lead I ECG signal as well as to implement heart rate detection algorithm.

C. Wireless Technology Implementation

The core communication of the ECG monitoring system is done through the mobiles carried by both user and telemonitoring service provider. As our telemonitoring system targets on plain mobile phone handsets rather than iPhone or other high end handsets, the popular Nokia91 is chosen for this development. Most recent mobile phones support execution of miniature programs that utilize the mobile processing power. Java 2 Micro Edition (J2ME), .Net Compact Framework, Binary Runtime Environment for Wireless (BREW), Carbide C/C++ are some of the programming environments for mobile phone application development. J2ME is basically a subset of the Java platform designed to provide Java APIs for applications on tiny, small and resource-constrained devices such as cell phones, PDAs and set-top boxes. Among these languages J2ME is pervasively used, since the compact Java runtime environment, Kilobyte Virtual Machine (KVM), has been supported by a wide range of mobile phone handsets already. One major advantage of choosing Java is that a single program written in J2ME can be executed on a variety of mobile phones that support Java. Apart from the basic computation framework provided by KVM, each of the mobile phone also supports additional Java libraries for supporting additional functionalities such as Bluetooth connectivity, camera functionality and messaging services, etc. These additional libraries expose Application Programming Interfaces (APIs) to the programmer of the handset. J2ME architecture is composed of configuration and profile. Connected Limited Device Configuration (CLDC) defines the minimal functionalities required for a range of wireless mobile devices, e.g., mobile phone, PDA, Pocket PC, home appliances etc.

Signal acquired with the system and its associated Mexican Hat based CWT for scales 1 and 25. As it can be observed from the figure, at scale 1, all the low frequency components of the ECG are filtered and only the QRS complexes and the EMG noise remain. Oppositely, as only low frequency components of the ECG are present at scale 25, the resulting wave has a

cosine-like behavior, which has the peaks where the original signal has T waves. Mexican Hat mother wavelet has been chosen for the presented algorithm because it was the one having the best performance after many tests with different ECG recordings and different mother wavelets.

QRS complexes and EMG noise is used to eliminate low frequency baseline wandering, so that a simple peak detection algorithm can be applied to detect all the peaks of the obtained signal. Then, the peaks with amplitude equal or higher than $2/3$ of the maximum peak amplitude are classified as QRS complexes.

Next, the algorithm also classifies as QRS complexes the peaks with amplitude between $2/3$ and $1/3$ of the maximum peak amplitude only if they are followed by a peak in the scale 25, delayed between 150 and 350 ms, which indicate a T wave.

The remaining detected peaks at the scale 1 signal are discarded. Finally, if a detected peak has another higher QRS complex closer than 200 ms, it is also discarded because it is probably produced by noise, typically from the EMG.

The algorithm calculates the heart rate value every time a new data packet is received. Therefore, according to the system data rate and packet payload, it is calculated every 100 ms.

EXPERIMENTAL SET UP

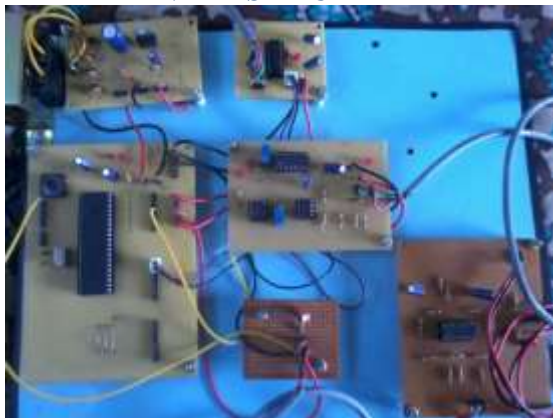

Fig 2. prototype model of proposed system

To characterize the robustness of an ECG heart rate detection algorithm, the most widely accepted parameters are sensitivity and positive predictivity. Sensitivity is defined as the amount of true detected beats over the real number of beats, whereas positive predictivity is defined as the amount of true detected beats over the number of detected beats. Those

parameters are calculated typically by testing the algorithm against the widely accepted ECG MIT-BIH arrhythmia database. Nevertheless, our algorithm has been specially designed to be robust against EMG noise because this is the main source of noise that is expected to distort the ECG signal when measured in our system. Due to this, to quantify its performance, we designed a specific test against EMG noise instead of using other more generic databases or procedures.

To do this, we used our system to acquire an ECG signal generated by a patient simulator (METRON PS-420) to which we added increasing levels of EMG noise. EMG noise was modeled as filtered additive white Gaussian noise (AWGN) in the band between 65 and 115 Hz, with a mean frequency of 90 Hz and a median frequency of 73 Hz.

Then, the EMG noise was band-pass filtered in the same bands of the acquisition system, and finally it was amplified in order to obtain the desired signal-to-noise ratio (SNR) and added to the reference ECG signal. The algorithm compared the detected peaks of the noisy signal with the ones detected in the reference signal to obtain the sensitivity and positive predictivity values.

The test was performed by using 60 s records for 40 SNR values from -5 to 15 dB, and it was repeated 10 times in order to average the results.

Apart from testing the performance of the system against EMG noise, it was also tested with ECG signals acquired with the collaboration of twelve test subjects of different age, gender, weight or physical condition. The physical condition was classified in four main groups: A first group (G1) including the people who make sport 5 or more days per week and follows a specific training plan or makes sport at professional level, a second group (G2) including the people who usually make sport more than one day per week but without following a specific training plan, a third group (G3) composed by people who usually make sport one day per week and a last group (G4) that includes those who usually do not make sport. Table I shows the specific characteristics of the test subjects.

The 12 subjects were asked to relax, to sit and to hold the system without make excessive effort and to avoid talking or moving. After waiting for 5 s to allow the system to stabilize, a 60 s recording was performed for each subject.

EXPERIMENTAL RESULTS

EMG levels from -5 to 15 dB of SNR in the test of robustness of the algorithm against EMG noise. As it is shown in the figure, the algorithm had an acceptable level of performance (95%) in both

indicators for SNR levels as low as 5 dB, which are only expected to be reached when making an excessive pressure or keeping the arms in tension. An additional EMG test was performed with a test subject trying to get the maximum EMG level, for which a 60 s signal was recorded. A 10 s sample of the acquired signal in which a much higher level of EMG noise was obtained than the one which was typical in normal use recordings

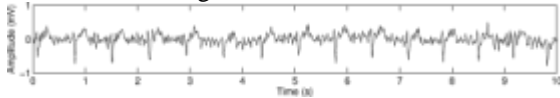

Fig 3. Lead I ECG recording containing a high degree of EMG noise.

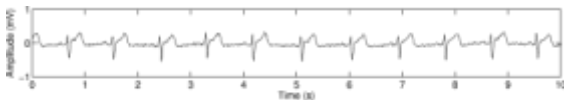

Fig.4. Typical Lead I ECG acquired with the prototype

The obtained values of sensitivity and positive predictively were 92.2% and 93.3%, respectively, which are acceptable considering the extreme conditions in which the signal was acquired.

From the typical recordings obtained during normal use of the system, it can be observed that the Lead I ECG is acquired with a quality which is good enough to clearly distinguish the main features and characteristic peaks of the ECG signal. This shows the usefulness of the system as a device to allow remote inspection of ECG recordings in home monitoring medical applications. To estimate also the effect of the mean EMG noise present in the system on abnormal ECG signals, three characteristic abnormal ECG patterns due to three different ECG arrhythmias were generated with the patient simulator to which EMG noise was added using the procedure described. The typical system EMG interference level was estimated as the average of the measured noise levels in several intervals between two consecutive T and P waves (where no significant ECG signal for all the ECG records from the test records acquired sig can be found) for all the ECG records of the test subjects in Table I. It can be observed from the figure that the characteristic shapes corresponding to these arrhythmias can be clearly identified, suggesting that the device can be used also to monitor abnormal ECG shapes when required for the desired application. On the other hand, the time needed to observe a stable ECG signal in the PC after a subject has placed the hands on the steering wheel was below 5 s in all the measurements performed. This confirms that the system developed constitutes a fast easy-to-use method to obtain the ECG signal, as required. Table

II shows the results for the heart rate detection algorithm when tested for the 12 subjects with different age, gender, weigh or physical condition. It can be observed that the heart rate detection algorithm had a good overall performance in the test in terms of positive predictivity (100.00%) and sensitivity (99.75%) for the several groups of test subjects studied, as no false positives and only two false negatives were obtained over a total amount of 823 beats. Considering the effect on sensitivity or on positive predictivity of one single false positive or negative over the total amount of beats, the resolution of both results can be estimated to be of 0.12%, thus confirming that the system achieves the necessary level of performance under typical use conditions

CONCLUSION

In this work, a novel easy-to-use system intended for the fast and noninvasive monitoring of the Lead I ECG signal by using a wireless steering wheel has been presented, together with a novel heart rate detection algorithm based on the CWT. The system uses a wireless steering wheel node containing four electrodes in a dual ground electrode configuration connected to a low-power analog front-end to reduce 50/60 Hz interference and to send the data to an access point connected to a PC. The Lead I ECG acquired in the hands is then shown in the PC with good enough quality for monitoring purposes. The system needs less than 5 s to obtain a stable ECG recording and has an overall current consumption of 2.5 mA.

The novel heart rate detection algorithm has been specially designed to show a robust performance against the most characteristic noise sources that are likely to be present in the designed system, mainly EMG noise and baseline wandering. Tests of performance under non-ordinary high levels of EMG noise have shown that the algorithm is able to achieve a good performance even in those extreme conditions. On the other hand, the tests performed with twelve test subjects of different age, gender, and physical condition have yielded a positive predictivity value of 100.00% and a sensitivity of 99.75%.

The presented system is expected to offer a competitive alternative for short-term ECG and heart rate monitoring in those situations in which easiness of use or also preparation and acquisition times were critical. The applications could include ECG monitoring in domestic or other non-clinical environments as well as its use as a fast and simple method for a first ECG acquisition in clinical environments.

REFERENCES

1. Joan Gómez-Clapers and Ramon Casanella, *Member, IEEE*. "A Fast and Easy-to-Use ECG Acquisition and Heart Rate Monitoring System Using a Wireless Steering Wheel" *IEEE Sensors Journal*, VOL. 12, NO. 3, MARCH 2012
2. I. Korhonen, J. Parkka, and M. Van Gils, "Health monitoring in the home of the future," *IEEE Eng. Med. Biol.*, vol. 22, no. 3, pp. 66–73, May/June. 2003.
3. M. Ishijima, "Unobtrusive approaches to monitoring vital signs at home," *Med. Bio. Eng. Comput.*, vol. 45, pp. 1137–1141, 2007.
4. N. Güler and U. Fidan, "Wireless transmission of ECG signal," *J. Med. Syst.*, vol. 30, pp. 231–236, 2006.
5. C. Lin, K. Chang, C. Lin, C. Chiang, S. Lu, S. Chang, B. Lin, H. Liang, R. Chen, Y. Lee, and L. Ko, "An intelligent telecardiology system using a wearable and wireless ECG to detect atrial fibrillation," *IEEE Trans. Inf. Technol. B.*, vol. 14, no. 3, pp. 726–733, May 2010.
6. H. Wang, D. Peng, W. Wang, H. Sharif, H. Chen, and A. Khojenezhad, "Resource-aware secure ECG healthcare monitoring through body sensor networks," *IEEE Wirel. Commun.*, vol. 17, no. 1, pp. 12–19, Feb. 2010.
7. D. Bansal, M. Khan, and A. K. Salhan, "A computer based wireless system for online acquisition, monitoring and digital processing of ECG waveforms," *Comput. Biol. Med.*, vol. 39, pp. 361–367, 2009, 4.
8. R. Fensli, E. Gunnarson, and O. Hejlesen, "A wireless ECG system for continuous event recording and communication to a clinical alarm station," in *Proc. IEEE EMBS 26th Annu. Conf.*, 2004, pp. 2208–2211.
9. V. Nopparat and P. Keeratiwintakorn, "The three-lead wireless ECG in sensor networks for mobile patients," in *Proc. SICE Annu. Conf.*, 2008, pp. 2308–2311.
10. S. Lee, J. Kim, J. Kim, and M. Lee, "A design of the u-health monitoring system using a nintendo DS game machine," in *Proc. IEEE EMBS 31th Annu. Conf.*, 2009, pp. 1695–1698.
11. C. Park, P. H. Chou, Y. Bai, R. Matthews, and A. Hibbs, "An ultra-wearable, wireless, low power ECG monitoring system," in *Proc. IEEE BioCAS*, 2006, pp. 241–244.
12. D. Higashi, T. Imai, A. Ueno, and O. Miyashita, "A wearable capacitive heart-rate monitor for controlling electrically assisted bicycle," in *Proc. ICEMS*, 2009, pp. 1–6.
13. Y. M. Chi and G. Cauwenberghs, "Wireless non-contact EEG/ECG electrodes for body sensor networks," in *Proc. Int. Conf. Body Sensor Netw. (BSN)*, 2010, pp. 297–301.
14. A. Searle and L. Kirkup, "A direct comparison of wet, dry and insulating bioelectric recording electrodes," *Physiol. Meas.*, vol. 21, pp. 271–283, 2000.
15. D. Díaz, . Casas, and R. Pallàs-Areny, "Interference reduction in ECG recordings by using a dual ground electrode," in *Proc. XIX IMEKO World Congr. Fundam. Appl. Metrology*, 2009, pp. 1695–1700.
16. J. C. Huhta and J. G. Webster, "60-Hz Interference in Electrocardiography," *IEEE Trans. Biomed. Eng.*, vol. 20, no. 2, pp. 91–101, Mar. 1973.
17. J. B. Mark, *Atlas of Cardiovascular Monitoring*. New York: Churchill Livingstone, 1998.
18. O. Casas, E. M. Spinelli, and R. Pallas-Areny, "Fully differential AC-coupling networks: A comparative study," *IEEE Trans. Instrum. Meas.*, vol. 58, no. 1, pp. 94–98, Jan. 2009.
19. H. Alemdar and C. Ersoy, "Wireless sensor networks for healthcare: A survey," *Comput. Netw.*, vol. 54, pp. 2688–2710, Oct. 28, 2010.
20. M. R. Yuce, "Implementation of wireless body area networks for healthcare systems," *Sensor. Actuat. A-Phys.*, vol. 162, pp. 116–129, 2010, 7.
21. P. S. Addison, "Wavelet transforms and the ECG: A review," *Physiol. Meas.*, vol. 26, pp. R155–R199, Oct. 2005.
22. C. Li, C. Zheng, and C. Tai, "Detection of ECG characteristic points using wavelet transforms," *IEEE Trans. Biomed. Eng.*, vol. 42, no. 1, pp. 21–28, Jan. 1995.

23. J. Fernandez, M. Harris, and C. Meyer, "Combining algorithms in automatic detection of R-peaks in ECG signals," in *Proc. 18th IEEE CBMS*, 2005, pp. 297–302.
24. J. Pan and W. J. Tompkins, "A real-time QRS detection algorithm," *IEEE Trans. Biomed. Eng.*, vol. 32, no. 3, pp. 230–236, Mar. 1985. [25] L. Sörnmo and P. Laguna, "Spectral analysis of the surface EMG," in *Bioelectrical Signal Processing in Cardiac and Neurological Applications*. Amsterdam, The Netherlands: Elsevier/Academic Press, 2005, pp. 361–364.